





# GENUINE REAR STABILIZER

## INSTALLATION AND USER'S INSTRUCTIONS

Thank you for purchasing a genuine Mazda accessory.  
Before removal and installation, be sure to thoroughly read these instructions.  
Please read the contents of this booklet in order to properly install and use the rear stabilizer. Your safety depends on it.  
Keep these instructions with your vehicle records for future reference.

### **WARNING**

- There are several  **WARNING** and  **CAUTION** sections in this booklet concerning safety when installing or removing the rear stabilizer. Always read and follow them in order to prevent injuries, accidents, and possible damage to the vehicle.
  -  **WARNING:** Indicates a situation in which serious injury or death could result if the warning is ignored.
  -  **CAUTION:** Indicates a situation in which bodily injury or damage to the vehicle could result if the caution is ignored.
- Do not modify the rear stabilizer.
- Do not install the rear stabilizer in any way other than described in the following instructions.
- If in any doubt, please ask your Mazda dealer to install the accessory in order to prevent errors in installation.
- If you have any questions about the use of the accessory, ask your Mazda dealer for proper advice before using it.
- Mazda and its suppliers are not responsible for injuries, accidents, and damage to persons and property that arise from the failure of the dealer or installer to follow these instructions.
- To ensure safety and reliability of the work, installation, removal and disposal work must be carried out by an Authorized Mazda Dealership.
- Be careful not to lose removed parts, and be sure that they are kept free from scratches, grease or other dirt.

**PART NAME: REAR STABILIZER**

**PART NUMBER: QSEA 28 151**

**VEHICLE: Mazda RX-8**

#### **NOTE**

##### **To the dealer**

- Please turn over these instructions to the customer after installation.

##### **To the customer**

- Keep these instructions after installation. The instructions may be necessary for installing other optional parts or removal of this accessory.
- Should the vehicle or this accessory be resold, always leave these instructions with it for the next owner.

# 1 PARTS

## Note

- Verify that the kit includes all the following parts and that they are free of dirt, scratches, or damage.

Part name	Qty.
Rear stabilizer	1

# 2 BEFORE INSTALLATION

## REQUIRED TOOLS

Prepare the following tools or items before installation.

- ★Wrench
- ★Rubber grease

# 3 ORIGINAL REAR STABILIZER REMOVAL

1. Remove the following parts in the order indicated in the figure.

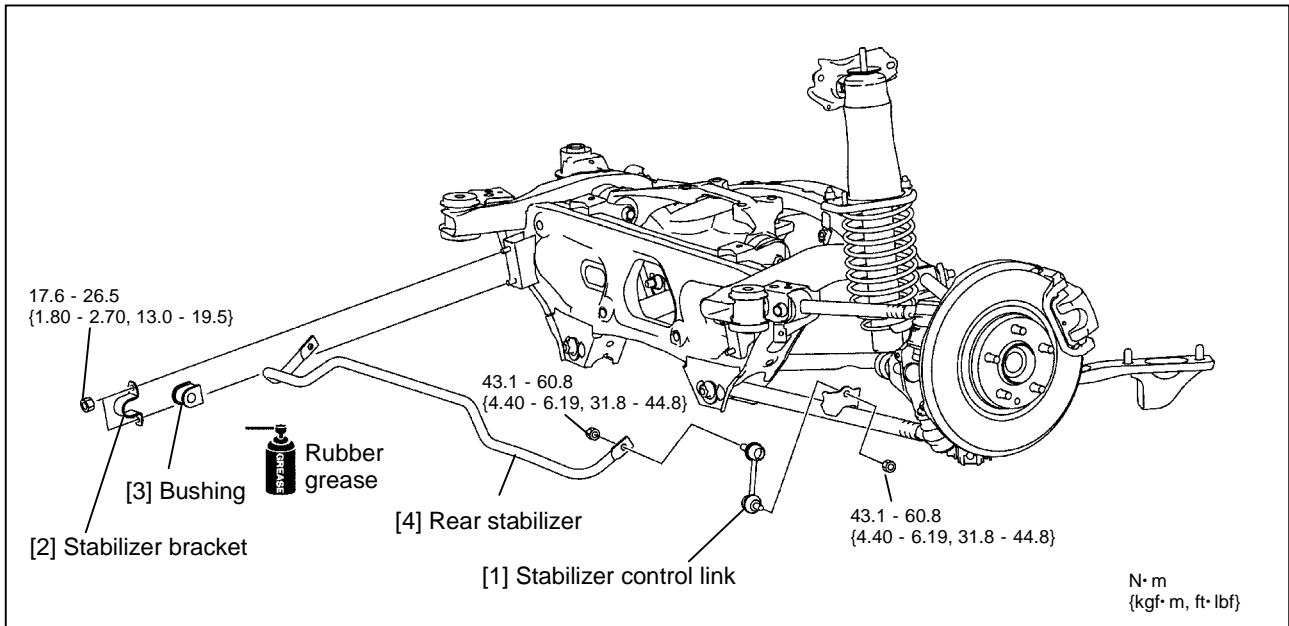

# 4

## REAR STABILIZER INSTALLATION

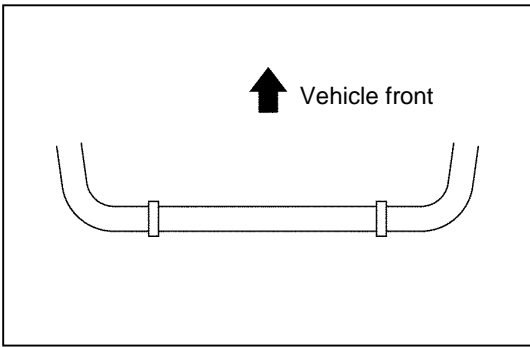

### Rear stabilizer installation

1. Align with the direction and shape of the standard stabilizer, and then install.

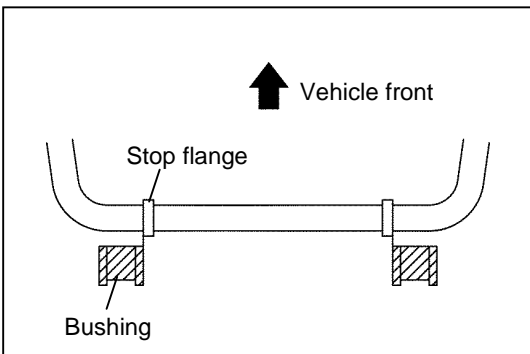

### Bushing installation

1. Install the bushings so that they are aligned with the stop flanges.

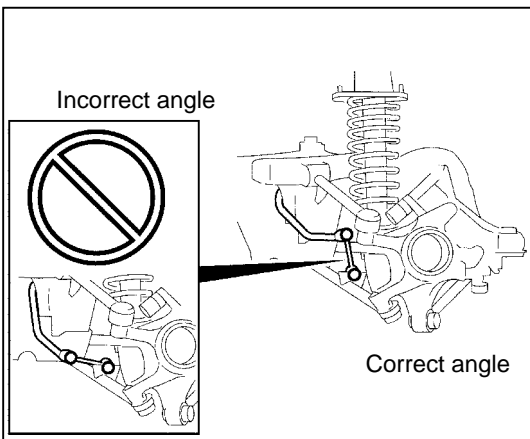

### Stabilizer control link installation

1. Install the stabilizer control link at the proper angle as shown in the figure.

#### ⚠ CAUTION

- Be sure to install the stabilizer control link in the proper position. If it is not installed properly, the stabilizer control link may interfere with peripheral components when driving, causing damage to each other.

### Removed parts reinstallation

1. Reinstall the parts removed in section [3] in the reverse or order of removal.